

- 主要用於保護壓力感測器. 儀表. 開關和傳送器
- 內部填充耐高溫油體
- 可分散源頭的溫度，產生冷卻效果



規格特性

- ◆ 材質: AISI 316 Stainless Steel
- ◆ 管徑尺寸: Schedule 40\*/ 80\*/ 160\*
- ◆ 操作溫度: Carbon steel : 150 kg/cm<sup>2</sup> at 430 °Cmax.  
Stainless steel : 135 kg/cm<sup>2</sup> at 450 °Cmax.

選用型號規格

BCF- 代碼1 - 代碼2

碼1	本體外型	碼2	管徑尺寸
C	Coil	4	1/2" Sch 40
P	Pigtail	8	1/2" Sch 80
U	U type	16	1/2" Sch 160

尺寸圖

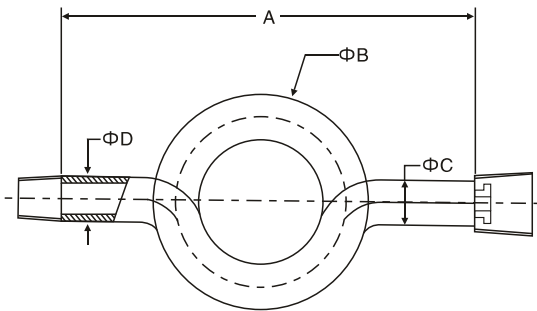

碼2	Pipe size	A	ΦB	ΦC	ΦD	E
4	1/2" Sch.40	240	58	21.3	15.7	25
8	1/2" Sch.80	240	58	21.3	13.9	25
16	1/2" Sch.160	240	58	21.3	11.7	25

Coil Type

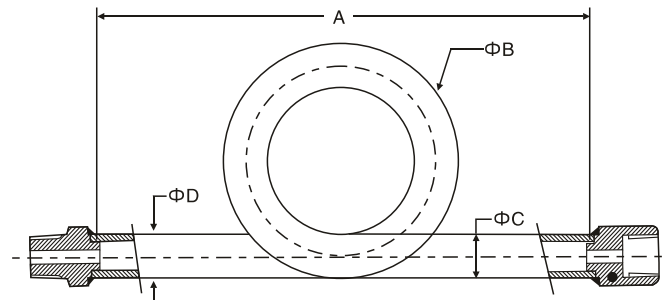

碼2	Pipe size	A	ΦB	ΦC	ΦD	E
4	1/2" Sch.40	240	110	21.3	15.7	25
8	1/2" Sch.80	240	110	21.3	13.9	25
16	1/2" Sch.160	240	110	21.3	11.7	25

Pigtail Type

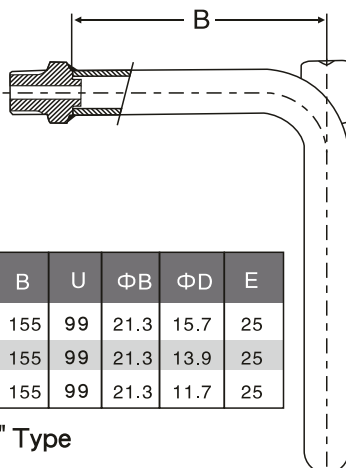

碼2	Pipe size	A	B	U	ΦB	ΦD	E
4	1/2" Sch.40	180	155	99	21.3	15.7	25
8	1/2" Sch.80	180	155	99	21.3	13.9	25
16	1/2" Sch.160	180	155	99	21.3	11.7	25

"U" Type

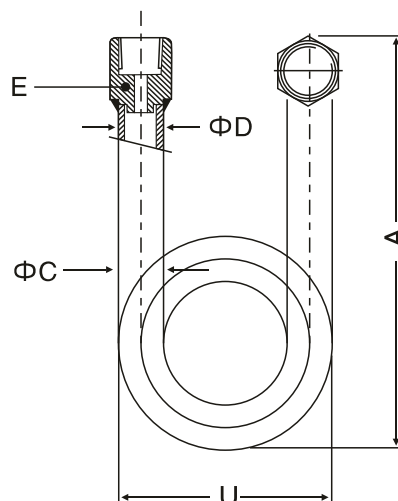

組裝圖

