

- Diameter: 44 mm
- Shaft: 6 mm
- Pulse per resolution up to 2500 PPR



SPECIFICATION

- ◆ Detection System: Incremental
- ◆ Output Wave: Square wave
- ◆ Output Phase: AB phase or ABZ phase
- ◆ Output Capacity: 20 mA
- ◆ Temperature Coefficient: 100ppm / °C (0~60°C)
- ◆ Operating Temperature: 0~60°C
- ◆ Operating Humidity: 20~90% RH (non-condensing)
- ◆ Storage Temperature: -10~70°C
- ◆ Storage Humidity: 20~90% RH (non-condensing)
- ◆ Power Supply: DC 8~26V, DC 5V
- ◆ Current Consumption: <60mA
- ◆ Waveform Rise/Fall: 2 usec
- ◆ Max. Frequency: 10KHz~100KHz
- ◆ Shaft Diameter: 6 mm
- ◆ Shaft Loading: Axial: 0.5Kgs; Radial: 1Kgs
- ◆ Starting Torque: 30 gf-cm (at 25°)
- ◆ Max. Speed: 6000 RPM
- ◆ Vibration: 10g (10 ± 1500Hz)
- ◆ Polarity: Against reverse protection (not with 5V)
- ◆ Shock: 20g/11msec
- ◆ Cable Length: 50 cm
- ◆ Weight: About 200 g

DIMENSION

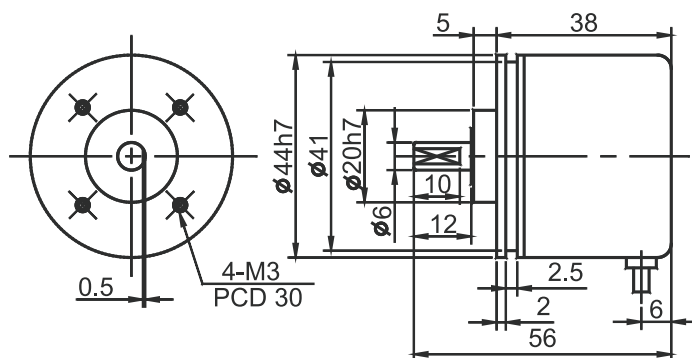

OUTPUT WAVEFORM

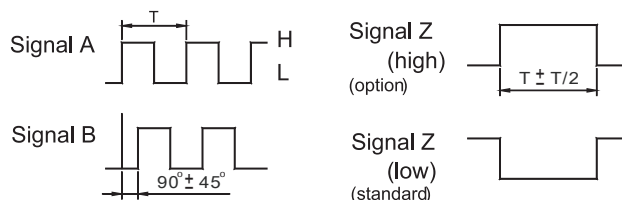

ORDER INFORMATION

HTR-W - [Code 1] - [Code 2] - [Code 3] - [Code 4]

Code1	Pulse per Resolution
10, 20, 30, 40, 50, 60, 80, 100, 120, 125, 150, 180, 200, 250, 300, 360, 400, 500, 512, 600, 720, 800, 1000, 1024, 1200, 1500, 1800, 2000, 2048	

Code2	Output Phase
2	AB Phase
3	ABZ Phase
3H	AB+Z Hi Phase

Code3	Output Waveform
Empty	Voltage
C	Open Collector
P	Push-Pull
L	Line-Driver 5Vdc
HL	Line-Driver 8~26Vdc

Code4	Aux. Power
Empty	DC 8~26V
5V	DC 5V

WIRING CONNECTION

● Voltage Type:

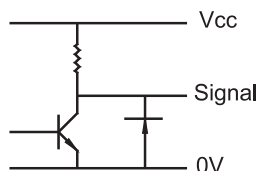

● Open-Collector:

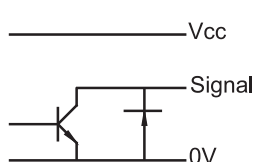

● Line Driver:

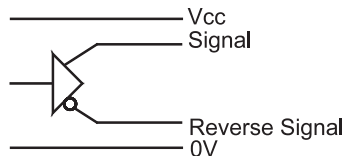

● Push-Pull:

