

- High quality, high-precision flow meter, using blade type rotation principle, Hall effect.
- Accuracy: $\pm 2\%$; Repeatability: $< \pm 0.8\%$.
- Measuring range: 1.5~100 l/h; 6~250l/h.
- Viscosity range: 1~10 Cst.
- High chemical resistance (ECTFE).
- **6mm, 8mm,9mm barb connection, easily installation.**
- K factor: 802 (9800pulse/ Liter), 804 (3500 pulse/ Liter)



SPECIFICATION

- ◆ Accuracy: $\pm 2\%$ from scale value
- ◆ Repeatability: $\pm 0.8\%$ from scale value
- ◆ Range: 1.5~100/h; 6~250l/h (H₂O at 22°C)
- ◆ Sensing Principle: Hall-Effect
- ◆ Viscosity Range: 1~10 cSt
- ◆ Max. Operating Pressure: 6 bar(POM), 10bar(ECTFE)
- ◆ Max. O/P Current (at 24V): 11mA
- ◆ Burst Pressure (at 22°C): >15 bar(POM), 30bar(ECTFE)
- ◆ Output Signal: Square wave (Push-Pull Output Stage)
- ◆ Operating Temperature: 0~80°C
- ◆ Power Supply: 4.5~24VDC
- ◆ Wiring Cable: Round cable3x0.14 mm LIYY
- ◆ Protection: IP65

ORDER INFORMATION

GS-80 - Code1 - Code2

Code1	Flow Range	Code2	Body Material
2	1.5~100 L/hour (6, 8mm barb)	P	POM
4	6~250 L/hour (9mm barb)	E	ECTFE

DIMENSION

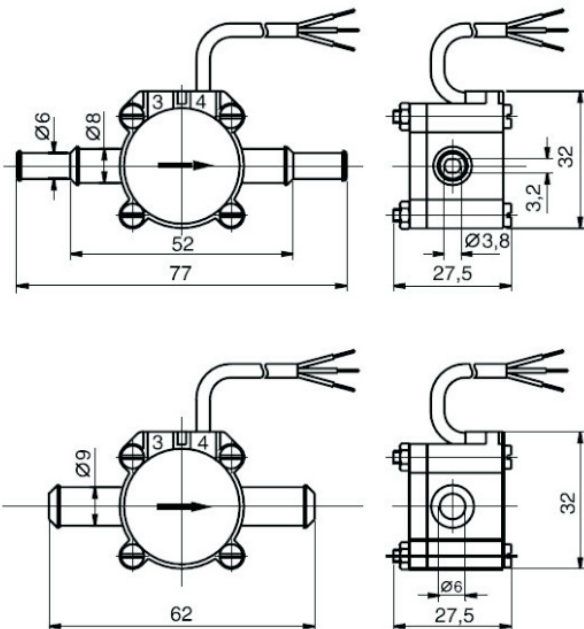

WIRING CONNECTION

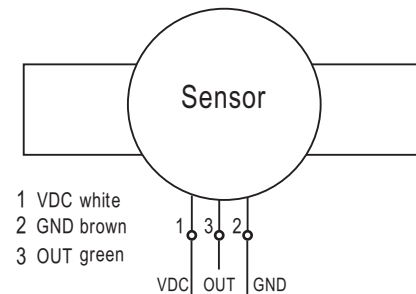

MATERIAL FEATURES

Materials	POM-Version	ECTFE-Version
Housing:	POM	ECTFE
Impeller:	POM	ECTFE
Bea ring (spigot bearing):		
for GS-80-2(axl e/bea ring):	Corepoi nt®/POM	Saphi r/Rub in
for GS-80-4(axl e/bea ring):	Corepoi nt®/POM	Saphi r/Rub in
Magnets:	sinter ceramic	ECTF E-encapsulated
O-Rings:	FKM or EPDM *	FKM or EPDM *
Weight:	appr ox. 45g	appr ox. 50g
Process connection:	1.5~100L: 6mm/ 8mm 6~250: 9mm	1.5~100L: 6mm/ 8mm

MATERIAL DESCRIPTION

POM (polyoxymethylene (plastic steel))

has good rigidity and toughness, good machinability, abrasion resistance, good impact resistance, good electrical properties, electrical insulation and poor weather resistance. Long-term exposure to ultraviolet rays will lead to the decline of mechanical properties, resulting in discoloration,

Cracked, or surface powdered, easily corroded by strong acids, strong alkalis and oxidants, resistant to a certain degree of weak acid

POM is easy to burn, even if the fire source is removed, POM will continue to burn

ECTFE (Ethylene Chlorotrifluoroethylene Copolymer)

The low temperature performance of this material is high in strength, abrasion resistance and creep resistance. It is resistant to most aggressive chemicals and organic solvents at room temperature and high temperature, and its performance is stable.

ECTFE does not catch fire and prevents flame spread

FKM (Fluororubber)

FKM is a fully synthetic polymer elastomer material, and fluororubber has high physical properties

Tensile strength and structural strength, high temperature resistance, fluororubber has excellent corrosion resistance, For organic solvents, inorganic acids, strong oxidants and oils have high corrosion resistance

EPDM (Ethylene propylene diene monomer)

The main characteristics are excellent heat resistance, ozone resistance and weather resistance.

It also has good resistance to polar substances and steam, and has excellent electrical insulation characteristics.

It is rigid at room temperature and will undergo elastic deformation under certain load.

After removing the pressure, the elasticity will restore it to its original shape.

At high temperature, the body will not undergo plastic change (no deformation),

It will not melt, but it can decompose.

INSTALLING NOTE

■ Standard installation diagram according to EN ISO 5167-1 (ID is for inner diameter)

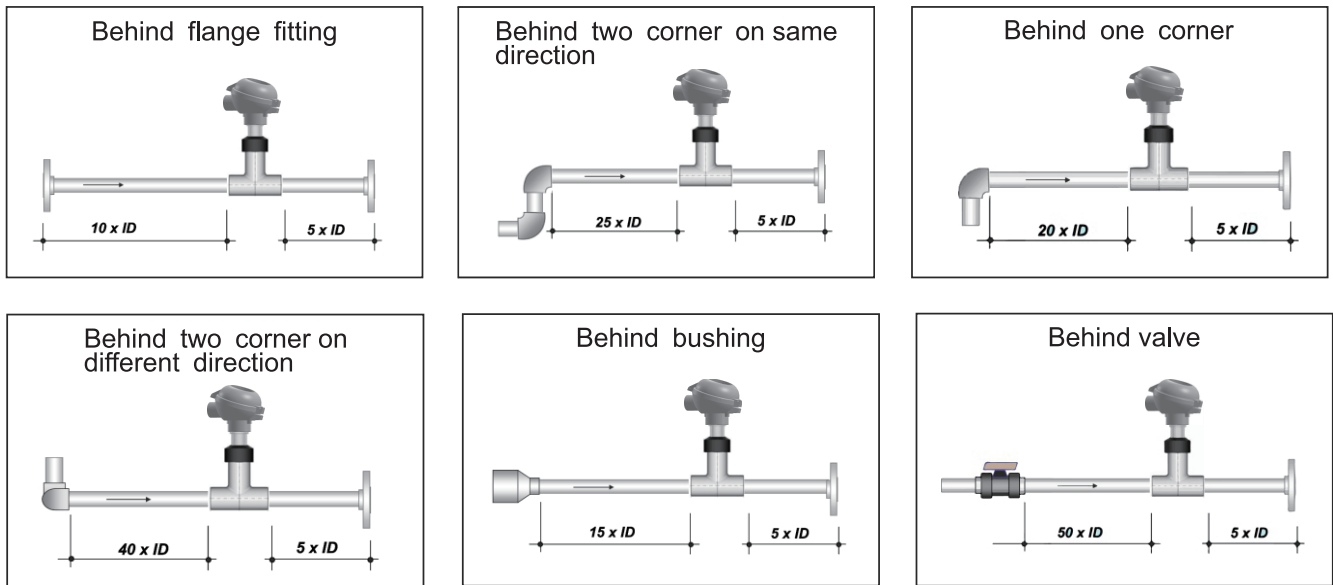

*If can not be suit this situation, please make the calibration of K factor.

■ Installation angle

-Installing in horizontal pipe system

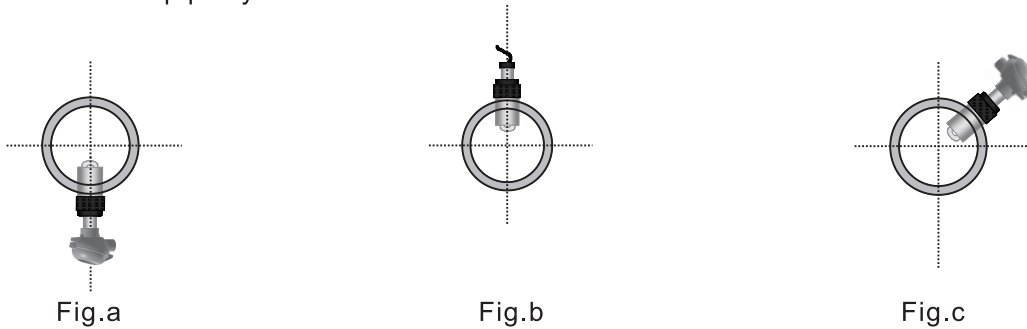

Fig.a: Installation for the pipe without sediment.

Fig.b: Installation for the pipe without bubble and must be full.

Fig.c: The best installation position can avoid the influences of sediment and bubble.

-Installing in vertical pipe system

It can be installed at any angle, the better installation flow direction is from bottom to top.

■ Installation Precautions

