

- Accuracy: $\pm 5\%$; Repeatability: $< \pm 1\%$
- Measuring range: 0.05~0.5 L/min; 0.2~5.0 L/min; 0.6~8.0 L/min
- Thread connection(1/4" BSP), easily installation

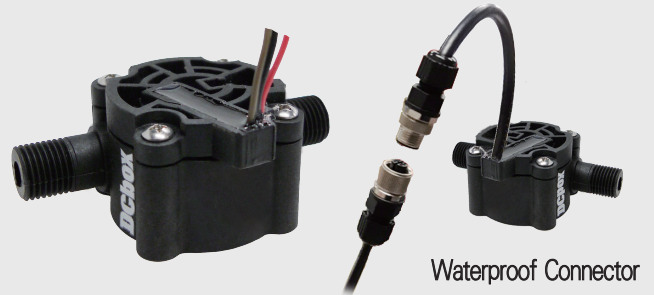

Waterproof Connector

DIMENSION

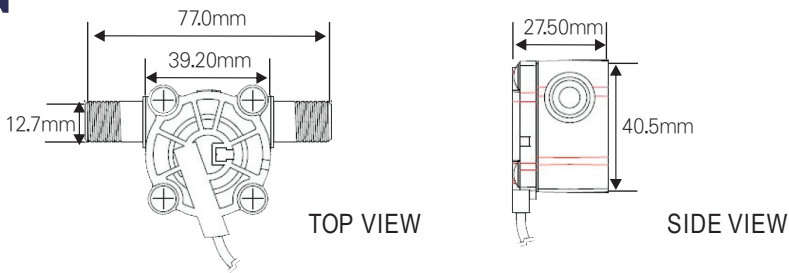

SPECIFICATION

- ◆ Accuracy: $\pm 5\%$ from scale value
- ◆ Repeatability: $\pm 1\%$ from scale value
- ◆ Range: 0.2~5.0L/min; 0.05~0.5Lmin (H₂O at 22°C)
- ◆ Sensing Principle: Hall-Effect
- ◆ Max. Operating Pressure: 8 bar
- ◆ Max. O/P Current (at 24V): 8mA Max.
- ◆ Burst Pressure (at 22°C): 30 bar
- ◆ Output Signal: Open Collect
- ◆ Operating Temperature: 0~30°C
- ◆ Power Supply: 2.4~26VDC
- ◆ Wiring Cable: Round cable3x0.14 mm² LIYY
- ◆ Protection: IP65

ORDER INFORMATION

SFL51 - Code1 - Code2

Code1	Flow range
3400	0.05-0.5 L/min
3200	0.2-5.0 L/min
3000	0.6-8.0 L/min

Code2	Wire Length
N	1.5M
5	5M
10	10M
O	Option

WIRING CONNECTION

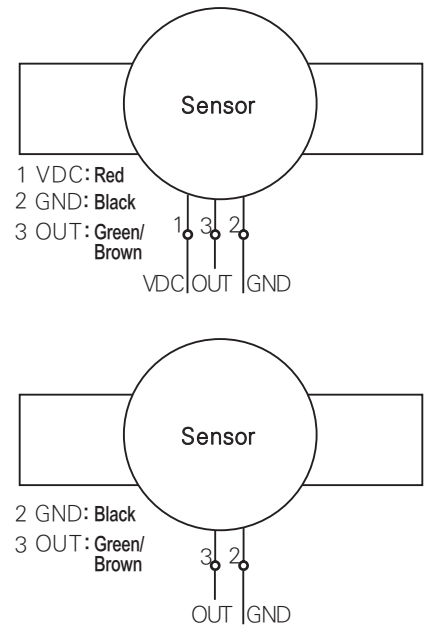

MATERIAL FEATURES

Materials	POM-Version
Housing	Nylon66
Impeller	POM
Stick of Turbine	SUS304
O-Rings	EPDM
Process Connection	1/4" BSP

K FACTOR TABLE

Flow range(L/min)	Pulse per Liter
0.05~0.5 L/min:	1560
0.2~5.0 L/min:	580
0.6~8.0 L/min:	250

INSTALLING NOTE

■ Standard installation diagram according to EN ISO 5167-1 (ID is for inner diameter)

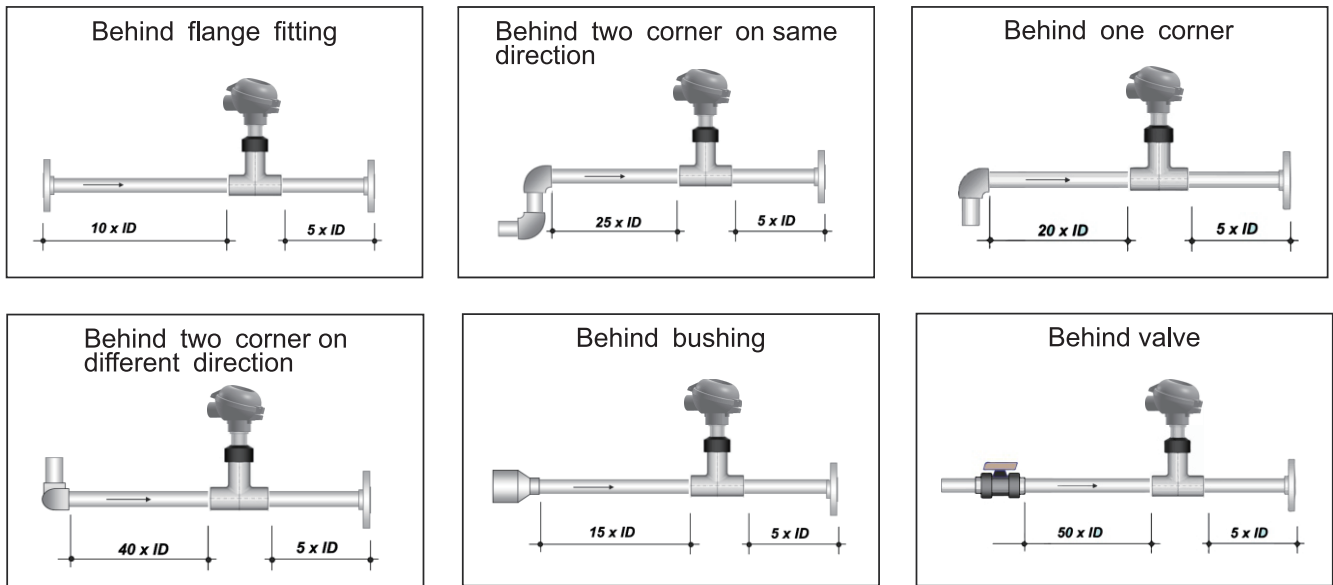

*If can not be suit this situation, please make the calibration of K factor.

■ Installation angle

-Installing in horizontal pipe system

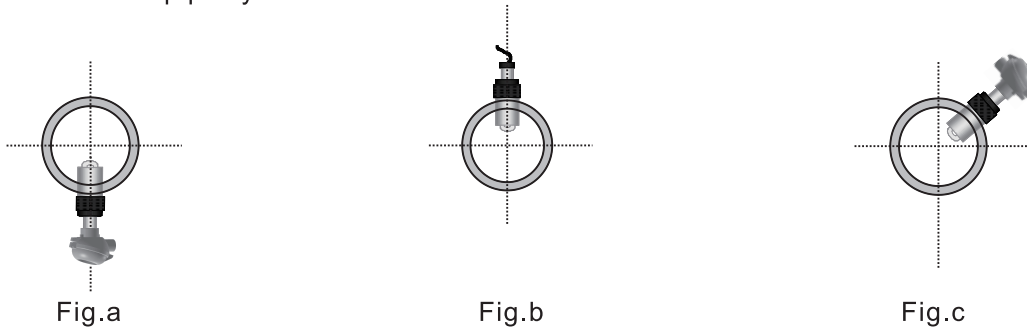

Fig.a: Installation for the pipe without sediment.

Fig.b: Installation for the pipe without bubble and must be full.

Fig.c: The best installation position can avoid the influences of sediment and bubble.

-Installing in vertical pipe system

It can be installed at any angle, the better installation flow direction is from bottom to top.

■ Installation Precautions

