



- Outdoor sun protection Waterproof (IP66).
- Customized installation of environmental sensors: wind speed Wind direction Sunshine...etc.
- Power supply: DC24V.
- With RS-485 (outgoing line below the screen).
- With Modbus RTU communication protocol.
- Can set various value exceeding alarm functions.

ORDER INFORMATION

ODP- Code1 - Code2 - Code3 - Code4

Code1	LED Display	Code2	Power	Code3	Communication	Code3	Alarm
13	1 row 3 digits	D	DC Power	N	None	R1	1 Relay
33	3 rows 3 digits	A	AC Power	Y	RS-485	R2	2 Relays
44	4 rows 4 digits					R3	3 Relays
54	5 rows 4 digits					R4	4 Relays
00	0 rows 0 digit					N	None

DIMENSION

● 5 rows 4 digits

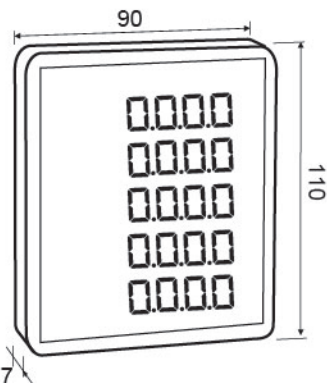

● 3 rows 3 digits

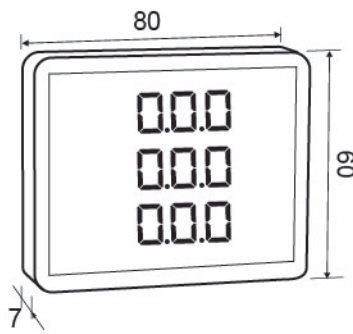

● 4 rows 4 digits

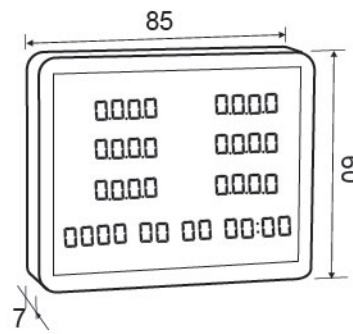

● 1 rows 3 digits

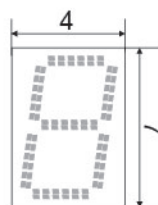
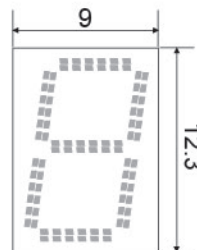
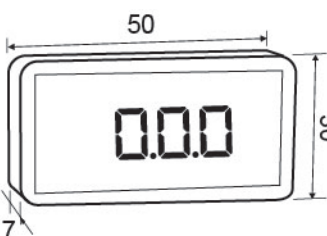

Unit: cm

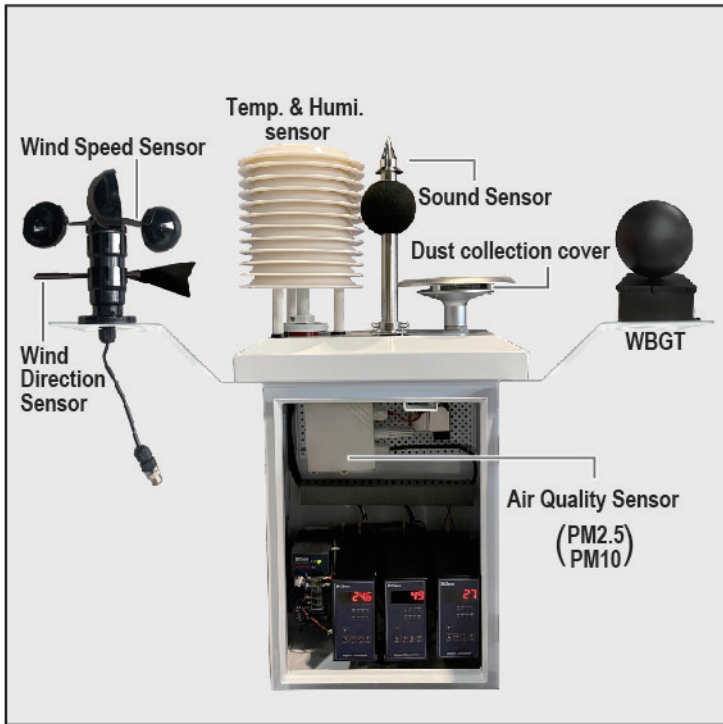

Temp. & Humi. sensor

- Humidity: 0~100%RH
- Temperature: 0~60°C

Sound Sensor

- Measure range: Up to 35dB~130dB
- Working environment: -20°C~+60°C, 0%RH~95%RH (non-condensing)
- Frequency: 20Hz~12.5kHz
- Accuracy: ±0.5dB (At reference pitch, 94dB@1kHz)

Air Quality Sensor

- Measure range: 0~1000µg/m³, Minimum measured particle size: 0.3µm
- Accuracy: ±10%(@500µg/m³, 60%RH, 25°C)

ORDER INFORMATION

ODS- - Code2 - Code3 - Code4

Code1 Sensor Type		
Select 3 or 5 (A~J)	(A) Temperature/ (B) Sound/ (C) PM2.5/ (D) PM10/ (E) Humidity/ (O) WBGT (F) Pyranometer/ (G) CO2/ (H) Anemometer/ (I) Anemoscope/ (J) Pressure *Refer to the official website	
Code2 Installation Type Code3 Alarm Code4 Communication		
A Snap-on	N None	N None
B U ring	R1 1 set of alarms each	Y RS-485
C L type		M RS-485
D XL type		



INSTALLATION ACCESSORIES

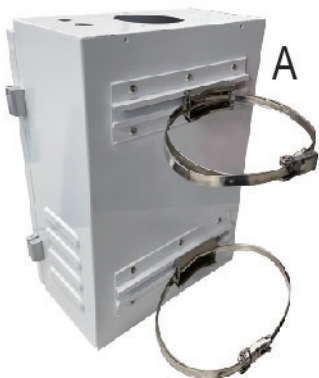

● 5 in 1: 400*500*200mm



● 3 in 1: 300*400*150mm

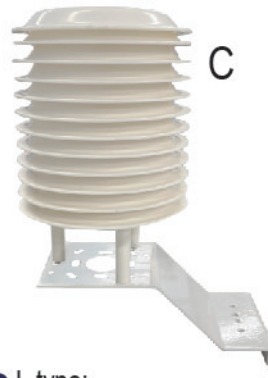

● L type: 91Φ*200mm(12 layer)

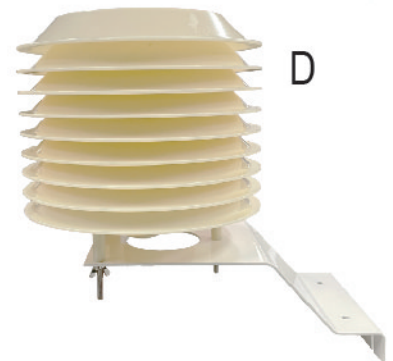

● XL type: 140Φ*255mm(9 layer)

- A Type-Snap-on (Diameter 50~350mm).
- B Type-U ring (Diameter 76mm/ 89mm/ 114mm/ 133mm) One set is divided into two groups(Upper and lower), including four M10 mounting screws.