

KEY FUNCTIONS

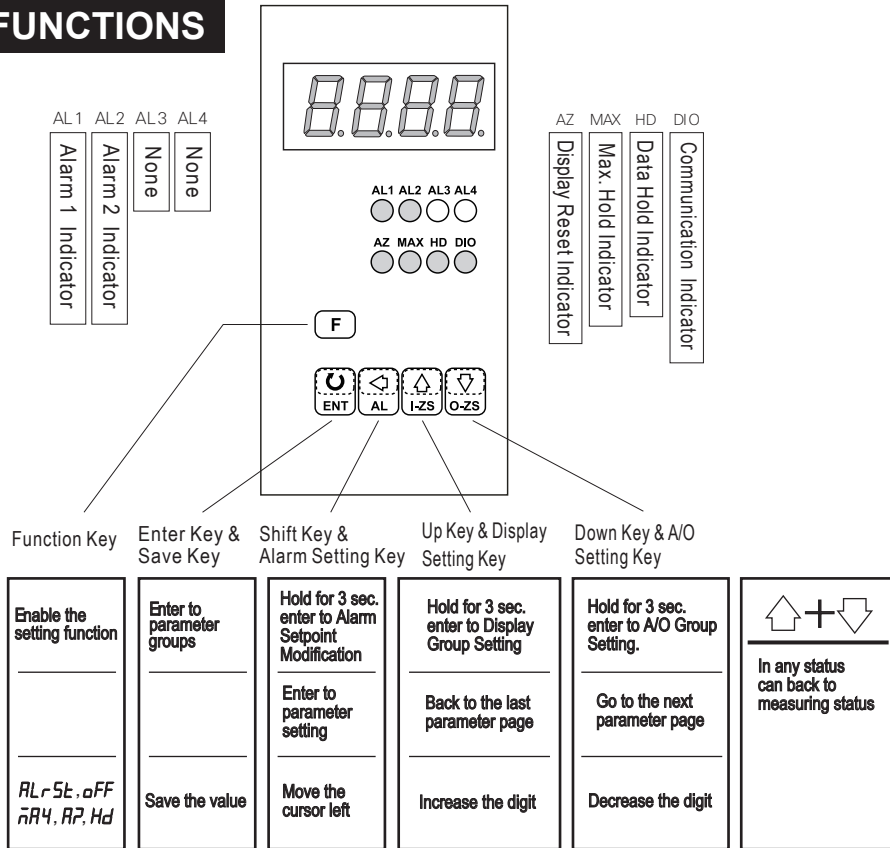

ERROR CODE OF SELF-DIAGNOSIS

- 10FL** Input signal is over 120% of input range.
- 10FL** Input signal is under -10% of input range.
- RdEr** Input signal is over 180% of input range or meter error.
- doFL** Input signal is over display range (999999).
- doFL** Input signal is under display range (-199999).
- E-00** EEPROM reading / writing suffers the interference (about 1 million times).

WIRING CONNECTION

Compound Input (S01,S02,S03,S04)

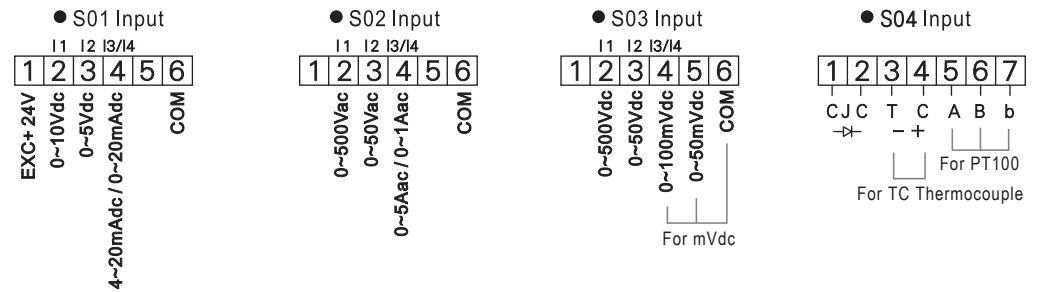

Input Function

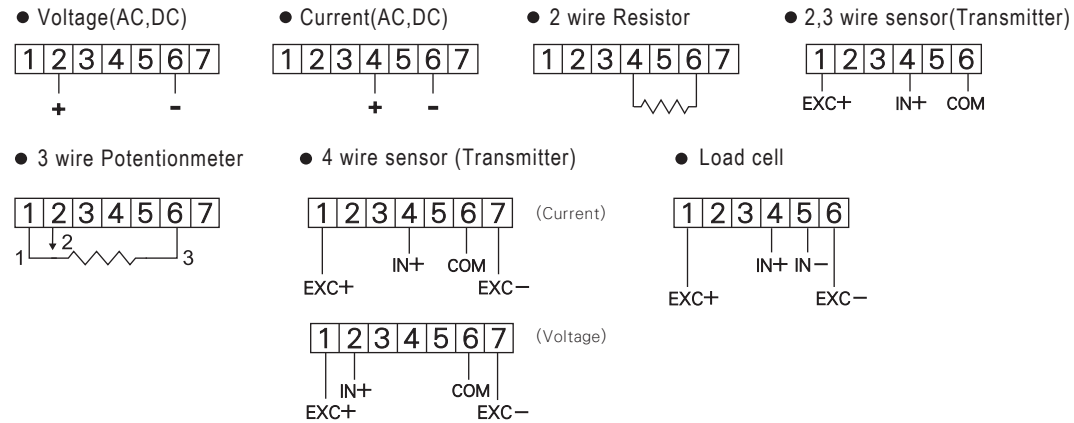

Output Function

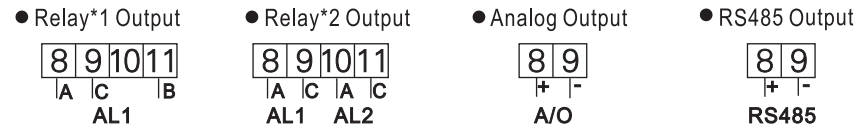

Power

