

- Capacity: 5-100t
- High Strength Alloy steel, High Precision, Oil-proof,
- Waterproof IP67
- Easy installation, suitable for electronic truck scales, Platform scales and other electronic weighing devices



SPECIFICATION

- ◆ Accuracy: 0.05%FS
- ◆ Rated Output(mv/v): 2.0 ±0.003
- ◆ Creep(%F.S/30min): ±0.05
- ◆ Repeatability %F.S ±0.05
- ◆ Hysteresis %F.S ±0.05
- ◆ Zero balance(%F.S): ±1.0
- ◆ Input resistance: 750±10
- ◆ Output resistance: 700±5
- ◆ Insulation resistance: ≥5000(100VDC)
- ◆ Temp. effect on span(%F.S/10°C): ±0.05
- ◆ Temp. effect on zero(%F.S/10°C): ±0.05
- ◆ Use temp. range(°C) : -30~+65
- ◆ Excitation voltage(V) : 9~12(DC)
- ◆ Safety overload (%F.S) 150%
- ◆ Ultimate overload (%F.S) 200%
- ◆ Defend grade IP67
- ◆ Cable Length: 5meters -20 meters

WIRING CONNECTION

	Color	Description
Input	Red	Input+
	Black	Input-
Output	Green	Output+
	White	Output-

DIMENSION (mm)

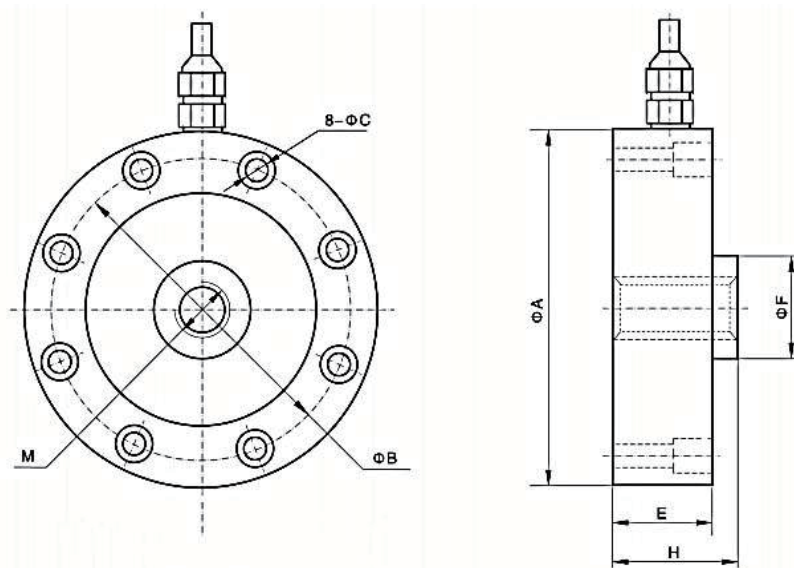

ORDER INFORMATION

DCL-03A- Code1

Code1	Capacity		
05	0.5t	30	30t
1	1t	50	50t
5	5t	100	100t
10	10t	O	Option
20	20t		

Capacity	ØA	ØB	ØC	ØF	M	H	E
0.5-7t	105	89	6.5	32	M16X1.5	37	34
10-25t	125	101.6	8.5	39	M32X1.5	52	48
30-50t	145	116.8	10.5	50	M40X1.5	58	54
60-100	205	162	12.5	80	M60X2	85	78