

- Accuracy: $\pm 0.2\%$ R.O.(PT-100).
 $\pm 0.3\%$ R.O.(K).
- Material class: A class.
- Response Time: 15 seconds.
- Certification: DIN IEC 60751.



SPECIFICATION

- ◆ Accuracy: $\pm 0.2\%$ R.O. (PT-100)
 $\pm 0.3\%$ R.O. (Thermocouple: K)
- ◆ Measuring Range: K: 0~1200°C
PT-100: -100~800°C
- ◆ Output Ripple: $\leq \pm 0.3\%$ R.O.
- ◆ Temperature Coefficient: 100ppm/°C (0~60°C)
- ◆ Operating Humidity: 20 to 90% RH (non-condensing)
- ◆ Storage Humidity: 20 to 90% RH (non-condensing)
- ◆ Input Impedence: Thermocouple: $\geq 1M\Omega$
PT-100: $\geq 10M\Omega$
- ◆ Material: Tube Thread: Steel 316
Head: Aluminum

ORDER INFORMATION

BTL-HP - Code1 Code2 - Code3 - Code4 Code5
- N - M8 - P

Code1	Input Type	Code3	Tube Length	Code4	Wiring Length
K	K Type	02	20 mm	03	3 M
P	RTD (PT-100)	03	30 mm	10	10 M
		04	40 mm	O	Option
		05	50 mm		
Code2	Tube Diameter	Code5	Wiring Material		
3	3.2 mm	06	60 mm	T	Teflon
5	5 mm	O	Option	F	Iron
6	6 mm			P	PVC

DIMENSION

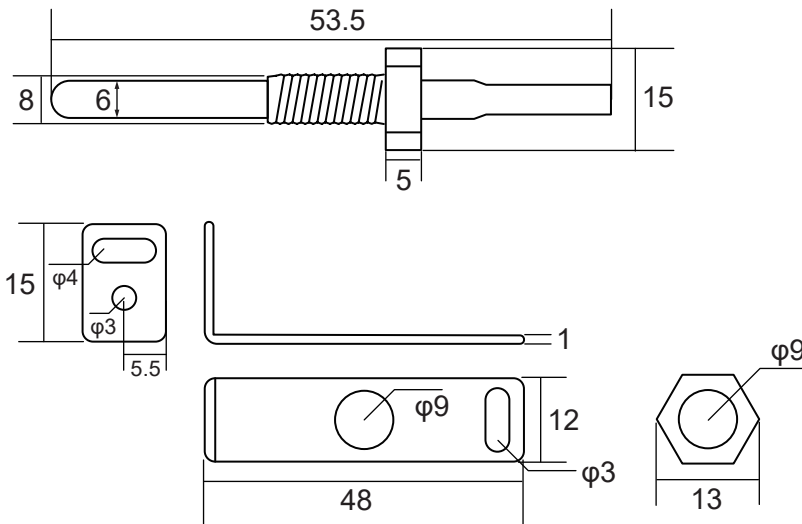

Unit: mm