

*Please understand key indicators & functions at the first operation.

FRONT PANEL & KEY FUNCTIONS

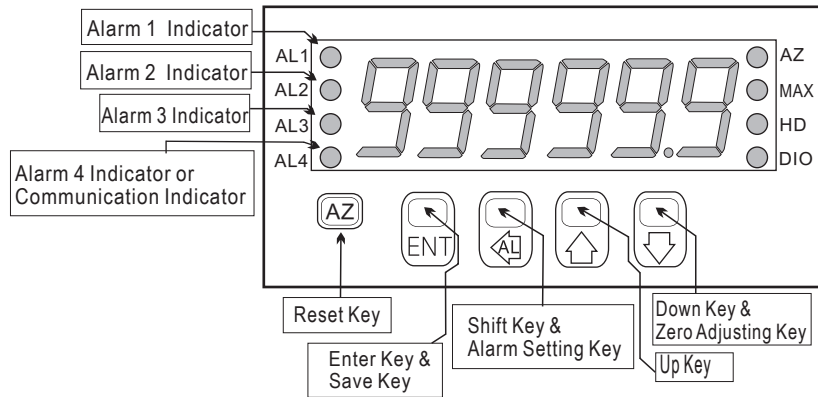

Key Name	Symbol	Descriptions
Reset Key	Ⓩ	1. Press this key to enable the reset function.
Enter Key & Save Key	ENT	1. In the measuring status, press this key can enter to parameter pages. 2. In the parameter setting, press this key can save the value & go to next parameter.
Shift Key & Alarm Setting Key	←AL	1. In the measuring status, press this key for 3 sec can enter to alarm setting page (The selecting digit will be flashed) 2. In the parameter setting, press this key can move the cursor left.
Up Key	↑	1. In the parameter setting, press this key can increase the digits.
Down Key & A/O Adjusting Key	↓	1. In the measuring status, press this key for 3 sec can enter to analog output adjustment. 2. In the parameter setting, press this key can decrease the digits.

- **1. The following block charts are parameters codes, parameter codes & parameters will alternate flashing if the parameters can be modified.
- 2. To modify the parameters, please press ←↑↓, and press ENT to save the parameter after the modification.
- 3. Please don't forget the new pass code after modification.
- 4. In any pages, press ↑&↓, or don't press any keys for 2 minutes that will back to measuring status.

GENERAL MODE OPERATING PROCEDURES

Block Charts	Display	Descriptions	Default
Alarm Setpoint			
Power ON	10000	Measuring Status	Present value for measurement
Press ← for 3 sec	AL 1	Alarm 1 Setpoint (AL1)	Press ←↑↓ to modify alarm 1 setpoint.
Press ENT	AL 2	Alarm 2 Setpoint (AL2)	Press ←↑↓ to modify alarm 2 setpoint.
Press ENT	AL 3	Alarm 3 Setpoint (AL3)	Press ←↑↓ to modify alarm 3 setpoint.
Press ENT	AL 4	Alarm 4 Setpoint (AL4)	Press ←↑↓ to modify alarm 4 setpoint.
Press ENT			
Analog Output: "ZERO" & "SPAN" Adjustment			
Power ON	10000	Measuring Status	The following steps are only available for analog output.
Press ↓ for 3 sec	APZero	A/O Zero Adjustment (AZero)	Press ← to select adjusting speed rate, press ↑ ↓ to modify the A/O zero. PS: To use this function to adjust the real A/O zero.
Press ENT	ASPan	A/O Span Adjustment (ASPan)	Press ← to select adjusting speed rate, press ↑ ↓ to modify the A/O span. PS: To use this function to adjust the real A/O span.
Press ENT			

- Remark: 1. There are 4 parameter groups of "System Setting Group(SYS)", "Alarm Setting Group(roP)", "Analog Output Setting Group (AoP)" & "RS485 Setting Group (doP)" for modification.
2. Press ← to select each group page, and press ENT to enter each group or parameter page for modification or saving the parameters.
3. Some of optional functions of parameter pages still exist, but the functions are disable.

PROGRAMMING MODE OPERATING PROCEDURES

Block Charts	Display	Descriptions	Default
Parameter Group Setting Procedures			
Power On	10000	Measuring Status	Present value for measurement
Press ENT	P.Cod	Pass Code (P.Cod)	Press ←↑↓ to enter pass code.
Press ENT	P.Code Correct		Pass code is correct that will enter to parameter groups. Pass code is wrong that will back to measuring status.
NO			
YES	555	(SYS)	
Press ←	roP	(roP)	
Press ←	RoP	(AoP)	
Press ←	doP	(doP)	
Press ENT	System Setting Group	Alarm Setting Group	A/O Setting Group
Press ENT			RS485 Setting Group

Display	Descriptions	Default
System Setting Group Procedures		
System Setting Page (SYS)		
595 Press: ENT dP	Decimal Point Setting (dP) Press $\uparrow\downarrow$ to select decimal point (0, 1, 2, 3, 4). EX: if the value shows "0.00" that means the decimal point is 2 digits.	Customers specify
Press: ENT tYPE	Input Type Setting (tYPE) Press $\uparrow\downarrow$ to modify the input type. (1U2D / 1P2D / 1A2B)	Customers specify
Press: ENT ACCU	1A2B Accurate Setting (ACCU) Press $\uparrow\downarrow$ to modify 1A2B accurate (X1, X4).	Customers specify
Press: ENT SCALE	Scale Coefficient Adjustment (SCALE) Press $\leftarrow\uparrow\downarrow$ to modify scale coefficient (0.0001 ~9.9999).	01.0000
Press: ENT div	Pre-Division Setting (div) Press $\uparrow\downarrow$ to modify pre-division (1~999999).	000001
Press: ENT CodE	Pass Code Setting (CodE) Press $\leftarrow\uparrow\downarrow$ to modify pass code (0~19999). PS: Please don't forget the new pass code after modification.	000000
Press: ENT LoCK	Key Lock Setting (LoCK) Press $\uparrow\downarrow$ to lock the keys, using key lock function only can view the parameters, but cannot modify any values. PS: no (unlock), YES ("ENT" unlock, others lock).	no
Press: ENT indi	Indicator 4 Setting (indi) Press $\uparrow\downarrow$ to modify indicator 4 for AL4 or DIO.	Customers specify
Alarm Setting Group Procedures		
roP	Alarm Setting Page (roP) The following steps are only available for alarm output.	
Press: ENT ACt1	Alarm Action Setting Alarm 1 (ACt1) Alarm 2 (ACt2) Alarm 3 (ACt3) Alarm 4 (ACt4)	Hi
Press: ENT ACt2		
Press: ENT ACt3		
Press: ENT ACt4		
Press: ENT oP.modE	Alarm Mode Setting (oP.ModE) Press $\uparrow\downarrow$ to modify alarm output mode (N, R, C). N: manual; R: return; C: continue	n
Press: ENT oP.tiME	Alarm Run Time Setting (oP.tiME) Press $\leftarrow\uparrow\downarrow$ to modify alarm run time (1~99).	00001
A/O Setting Group Procedures		
RoP	A/O Setting Page (AoP) The following steps are only available for analog output.	
Press: ENT PoLARr	A/O Polarity Setting (PoLARr) Press $\uparrow\downarrow$ to select output for positive or negative pole. PS: Voltage output, NO: positive pole output (0~+10V) YES: positive & negative pole output (-10~+10V)	no
Press: ENT AnLo	A/O Low Scale Setting (AnLo) Press $\leftarrow\uparrow\downarrow$ to adjust A/O low scale to correspond to the display value (programmable). EX: A/O is 0~10V, the display is 10.0 to output 0V, this value must be set for 10.0.	000000
Press: ENT AnHi	A/O Hi Scale Setting (AnHi) Press $\leftarrow\uparrow\downarrow$ to adjust A/O hi scale to correspond to the display value (programmable). EX: A/O is 0~10V, the display is 90.0 to output 10V, this value must be set for 90.0.	999999

Display	Descriptions	Default
RS485 Setting Group Procedures		
doP	RS485 Setting Page (doP) The following steps are only available for RS-485.	
Press: ENT Addr	Address Setting (Addr) Press $\leftarrow\uparrow\downarrow$ to modify address (0~255).	000000
Press: ENT bAUd	Baud Rate Setting (bAUd) Press $\uparrow\downarrow$ to select baud rate (38400.19200.9600.4800)	19200
Press: ENT PAri	Parity Setting (PAri) Press $\uparrow\downarrow$ to select parity (n.8.2/n.8.1/even/odd).	n82
Press: ENT FrAmE	Frame Setting (FrAmE) Press $\uparrow\downarrow$ to select frame type. (NO:Hi→Lo, YES:Lo→Hi)	no

ERROR CODE OF SELF-DIAGNOSIS

Display	Descriptions
E-00	EEPROM reading/writing suffers the interference (about 1 million times).

**Please check the wiring connection is correct first, if the problem still exist, please return the meter to the factory.

**Relay Output Mode Descriptions:

- N: (Manual); the relay is on when the present value reaches the alarm setpoint, the present value is still counted and the relay don't deactivate until manual reset by "reset key" or "external control terminal". Then the present value is reset to zero.
- R: (Return); the relay is on when the present value reaches the alarm setpoint, the present value is counted until the relay output time is terminated. Then the present value is reset to zero.
- C: (Continue); the relay is on when the present value reaches the alarm setpoint, the present value is reset to zero. And the relay is still on until the relay output time is terminated.

INPUT SIGNAL MODIFICATION

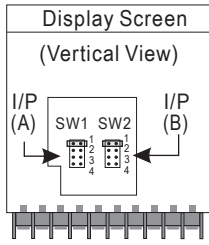

**To Select the pin to modify the input signal for different sensors.
PS: In dual input type, excitation power must be the same.

SW1	JUMPER	DEFINITION
● ●	1	Open: 12V; Close: 5V
● ●	2	Open: 10 KHz; Close: 400Hz
● ●	3	Open: NPN; Close: PNP
● ●	4	Open: PNP; Close: NPN

※Connection:

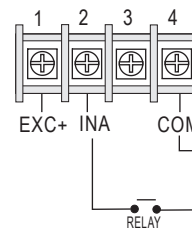

Relay Contact: NPN 0~400 Hz

JUMPER	SW1/SW2
1	● ●
2	■ ●
3	● ●
4	■ ●

**For relay input type, please select NPN 0~ 400 Hz.

※Connection:

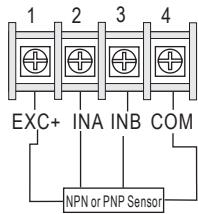

NPN (5V): 0~400 Hz

JUMPER	SW1/SW2
1	■ ●
2	■ ●
3	● ●
4	■ ●

NPN (5V): 0~10 KHz

JUMPER	SW1/SW2
1	■ ●
2	● ●
3	● ●
4	■ ●

NPN (12V): 0~400 Hz

JUMPER	SW1/SW2
1	● ●
2	■ ●
3	● ●
4	■ ●

NPN (12V): 0~10 KHz

JUMPER	SW1/SW2
1	● ●
2	● ●
3	● ●
4	■ ●

PNP (5V): 0~400 Hz

JUMPER	SW1/SW2
1	■ ●
2	■ ●
3	■ ●
4	● ●

PNP (5V): 0~10 KHz

JUMPER	SW1/SW2
1	■ ●
2	● ●
3	■ ●
4	● ●

PNP (12V): 0~400 Hz

JUMPER	SW1/SW2
1	● ●
2	■ ●
3	■ ●
4	● ●

PNP (12V): 0~10 KHz

JUMPER	SW1/SW2
1	● ●
2	● ●
3	■ ●
4	● ●

MODBUS RTU MODE PROTOCOL ADDRESS TABLE

Data: 16Bit / 32Bit, +/- is 8000~7FFF (-32768~32767), 80000000~7FFFFFFF(-2147483648~2147483647)				
Modbus	HEX	Name	Descriptions	Act
40001	0000	ID	Model number identification; AM6H-C is "06"	R
40002	0001	STATUS	Current alarm output & external control input status display; range: 0000~00F0 (0~240) (0:OFF, 1:ON) (Bit7:AL4, Bit6:AL3, Bit5:AL2, Bit4:AL1)	R
40003	0002	POLAR	Analog output polarity setting; range: 0000~0001 (0~1) 0:NO, 1:YES	R/W
40004	0003	LOCK	Key lock setting; range: 0000~0001 (0~1) 0:NO, 1:YES	R/W
40005	0004	FRAME	Frame setting; range 0000~0001(0~1) 0:NO, 1:YES	R/W
40006	0005	INDI	Indicator 4 setting; range 0000~0001(0~1) 0:AL4, 1:DIO	R/W
40007	0006	ACT1	Alarm 1 act setting; range: 0000~0001 (0~1) 0:HI, 1:LO	R/W
40008	0007	ACT2	Alarm 2 act setting; range: 0000~0001 (0~1) 0:HI, 1:LO	R/W
40009	0008	ACT3	Alarm 3 act setting; range: 0000~0001 (0~1) 0:HI, 1:LO	R/W
40010	0009	ACT4	Alarm 4 act setting; range: 0000~0001 (0~1) 0:HI, 1:LO	R/W
40011	000A	TYPE	Input type setting; range: 0000~0002 (0~1) 0:1U2D, 1:1P2D, 2:1A2B	R/W
40012	000B	ACCU	1A2B accurate setting; range 0000~0001(0~1) 0:X1, 1:X4	R/W
40013	000C	DP	Present Value decimal point setting; range: 0000~0005 (0~4) 0:10 ⁰ , 1:10 ¹ , 2:10 ² ~ 5:10 ⁵	R/W
40014	000D	OP.MODE	Count mode setting; range 0000~0002(0~2) 0:N, 1:R, 2:C	R/W
40015	000E	BAUD	Baud rate setting; range: 0000~0003 (0~3) 0:38400, 1:19200, 2:9600, 3:4800	R/W
40016	000F	PARI	Parity setting; range: 0000~0003 (0~3), 0:N.8.2., 1:N.8.1., 2:EVEN, 3:ODD	R/W
40017	0010	ADDR	Address setting; range: 0000~00FF (0~255)	R/W
40018	0011	OP.TIME	Present value relay output time setting; range: 0000~0063 (0~99)	R/W
40019	0012	AZERO	Analog output zero setting; range: D8F1~270F (-9999~9999)	R/W
40020	0013	ASPAN	Analog output span setting; range: D8F1~270F (-9999~9999)	R/W
40021	0014	CODE	Pass code setting; range: 00000000~000F423F (0~99999) Hi Bit	R/W
40022	0015		Pass code setting; range: 00000000~000F423F (0~99999) Low Bit	R/W
40023	0016	DIV	Pre-division setting; range: 00000001~000F423F (1~999999) Hi Bit	R/W
40024	0017		Pre-division setting; range: 00000001~000F423F (1~999999) Low Bit	R/W
40025	0018	SCALE	Total scale setting; range: 00000001~000F423F (1~999999) Hi Bit	R/W
40026	0019		Total scale setting; range: 00000001~000F423F (1~999999) Low Bit	R/W
40027	001A	ANLO	Analog output low scale setting; range: FFFCF2C1~000F423F (-199999~999999) Hi Bit	R/W
40028	001B		Analog output low scale setting; range: FFFCF2C1~000F423F (-199999~999999) Low Bit	R/W
40029	001C	ANHI	Analog output hi scale setting; range: FFFCF2C1~000F423F (-199999~999999) Hi Bit	R/W
40030	001D		Analog output hi scale setting; range: FFFCF2C1~000F423F (-199999~999999) Low Bit	R/W
40031	001E	AL1	Present value alarm 1 setpoint setting; range: FFFCF2C1~000F423F (-199999~999999) Hi Bit	R/W
40032	001F		Present value alarm 1 setpoint setting; range: FFFCF2C1~000F423F (-199999~999999) Low Bit	R/W
40033	0020	AL2	Present value alarm 2 setpoint setting; range: FFFCF2C1~000F423F (-199999~999999) Hi Bit	R/W
40034	0021		Present value alarm 2 setpoint setting; range: FFFCF2C1~000F423F (-199999~999999) Low Bit	R/W
40035	0022	AL3	Present value alarm 3 setpoint setting; range: FFFCF2C1~000F423F (-199999~999999) Hi Bit	R/W

Modbus	HEX	Name	Descriptions	Act
40036	0023		Present value alarm 3 setpoint setting; range: FFFCF2C1~000F423F (-199999~999999) Low Bit	R/W
40037	0024	AL4	Present value alarm 4 setpoint setting; range: FFFCF2C1~000F423F (-199999~999999) Hi Bit	R/W
40038	0025		Present value alarm 4 setpoint setting; range: FFFCF2C1~000F423F (-199999~999999) Low Bit	R/W
40039	0026	PV	Current present value setting; range: FFFFB1E1~0001869F (-19999~99999) Hi Bit	R/W
40040	0027		Current present value setting; range: FFFFB1E1~0001869F (-19999~99999) Low Bit	R/W