

KEY FUNCTIONS

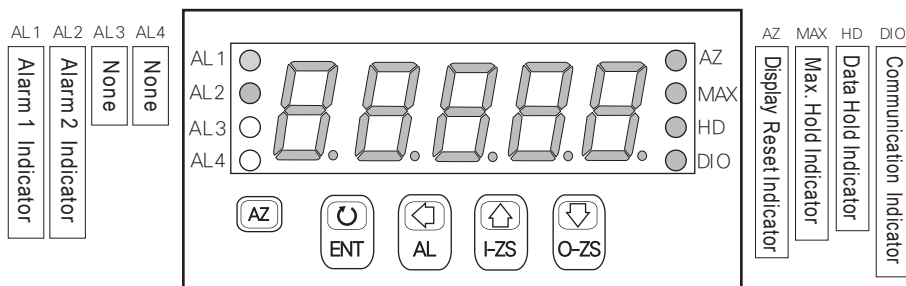

WIRING CONNECTION

Input Function

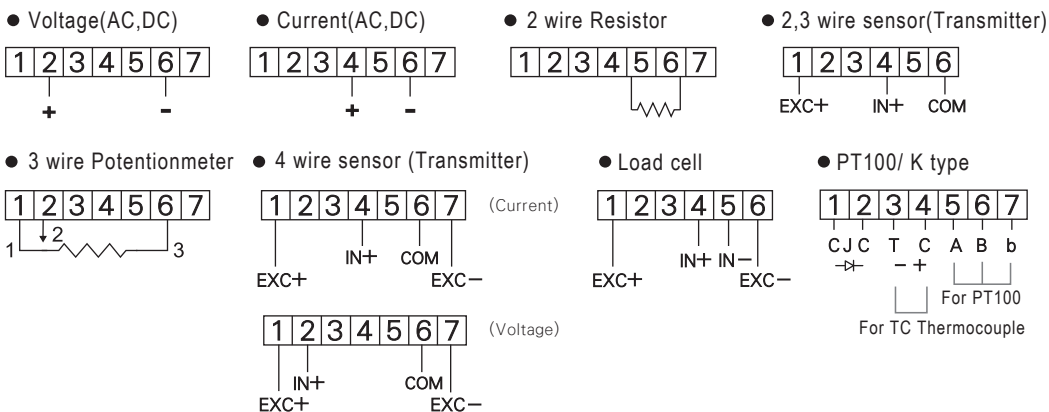

Output Function

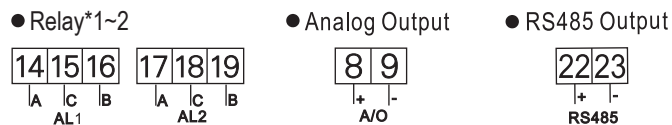

Power

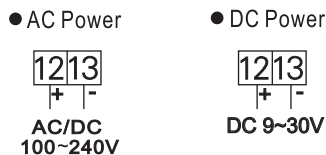

ERROR CODE OF SELF-DIAGNOSIS

- ioFL** Input signal is over 120% of input range.
- ioFL** Input signal is under -10% of input range.
- RdEr** Input signal is over 180% of input range or meter error.
- doFL** Input signal is over display range (999999).
- doFL** Input signal is under display range (-199999).
- E-oo** EEPROM reading / writing suffers the interference ( about 1 million times).

MODBUS RTU MODE PROTOCOL ADDRESS TABLE

Data: 16Bit / 32Bit, +/- is 8000~7FFF (-32768~32767), 80000000~7FFFFFFF(-2147483648~2147483647)

Modbus	HEX	Name	Descriptions	Act
40004	0003	DP	Decimal point setting; range: 0000~0004 (0~4) 0:10 <sup>0</sup> ; 1:10 <sup>1</sup> ; 2:10 <sup>2</sup> ; 3:10 <sup>3</sup> ; 4:10 <sup>4</sup>	R/W
40005	0004	BAUD	Baud rate setting; range: 0000~0005 (0~5) 0:2400, 1:4800, 2:9600, 3:19200, 4:38400, 5:57600	R/W
40006	0005	PARI	Parity setting; range: 0000~0003 (0~3), 0:N.8.1., 1:N.8.2., 2:EVEN, 3:ODD	R/W
40007	0006	AVG	Display average setting; range: 0001~0063 (1~99)	R/W
40009	0008	ADDR	Address setting; range: 0000~00FF (1~254)	R/W
40019	0012	CODE	Pass code setting; range: 00000000~0001869F(0~99999) Hi Bit	R/W
40020	0013		Pass code setting; range: 00000000~0001869F(0~99999) Low Bit	R/W
40021	0014	DSPL	Display low scale setting; range:FFFFB1E1~0001869F(-19999~99999) Hi Bit	R/W
40022	0015		Display low scale setting; range:FFFFB1E1~0001869F(-19999~99999) Low Bit	R/W
40023	0016	DSPH	Display hi scale setting; range:FFFFB1E1~0001869F(-19999~99999) Hi Bit	R/W
40024	0017		Display hi scale setting; range:FFFFB1E1~0001869F(-19999~99999) Low Bit	R/W
40026	0019	DISPLAY	Current display; range:FFFFB1E1~0001869F(-19999~99999) Hi Bit	R
40027	001A		Current display; range:FFFFB1E1~0001869F(-19999~99999) Low Bit	R
40031	001E	DISPLAY	Current display; range:FFFFB1E1~0001869F(-19999~99999) Hi Bit	R
40032	001F		Current display; range:FFFFB1E1~0001869F(-19999~99999) Low Bit	R
40039	0026	DISPLAY	Current display; range:FFFFB1E1~0001869F(-19999~99999) Hi Bit	R
40040	0027		Current display; range:FFFFB1E1~0001869F(-19999~99999) Low Bit	R

